

# CIRCULAR WILLOW | CIRCULAR WILLOW 150 PENDANT LAMP | CIR-WIL-150(SML)-PEN



## DESCRIPTION

A 150mm Dia. simple classic 'circular-Willow' pendant lamp. Illuminated by 1x G9 LED lamp within a handmade frosted or clear Pyrex glass diffuser, OR by 1x E12/14 or E26/27 vintage style LED bulb.

*See our Finishes & Materials page for all standard specs*

## PRODUCT SIZE

SHADE SIZE: 150W X 350-520H MM / TOTAL HEIGHT: 750MM

## PACKAGING DIMENSIONS

220MM(W) X 220MM(L) X 200MM(H)



## LAMP TYPE & NO

1X G9-2.5W LED  
OR 1X E12/14 OR E26/27 LED  
WARM WHITE - DIMMABLE

CLASS II  
IP RATING 20  
QC RATING 21

VOLTAGE RANGE  
111 - 240V

PRODUCT  
MARKS &  
RATINGS



WEIGHT 2KG  
PACKED 3KG  
WEIGHT

## TECHNICAL DRAWING

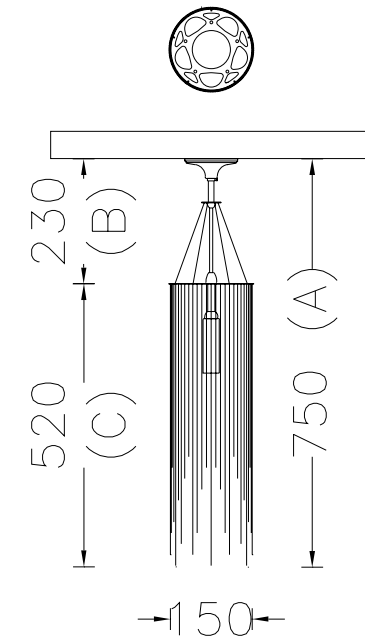

## INTERACT

### SELECT CHAIN FINISH

- SILVER \*
- BRASS \*
- COPPER \*
- SMOKE \*
- MIXED METALIC \*
- BLACK OXIDE †
- RUST OXIDE †
- WHITE \*
- RED \*
- BLACK \*

### CUSTOMISE DIMENSIONS

A

B

C

### LAMP TYPE

QUANTITY

### ADDITIONAL COMMENTS

[WEB LINK & DOWNLOAD](#)

\* LASERCUT FRAMES BRUSHED STAINLESS STEEL, BRASS CNC PARTS CHROME PLATED.

† LASERCUT FRAMES AND BRASS CNC PARTS IN MATCHING OXIDIZED FINISH.