

THREE-TIERED CHANDELEIRS | 3-TIER - 700 - SUSPENDED | 3-TIER-700-S



DESCRIPTION

A suspended chandelier based on a modern classic chandelier design, an arrangement of three semi-transparent cylindrical volumes. Made from laser-cut stainless steel frames, chrome plated or lacquered, solid brass components and ballchain in several optional finishes. Illuminated by 13 surface mounted G9 Halogen lamps.

PRODUCT SIZE

SHADE SIZE: 700W X 350H MM / TOTAL HEIGHT: 800MM

PACKAGING DIMENSIONS

810MM(W) X 810MM(L) X 330MM(H)



LAMP TYPE & NO

13 X G9-HALOGEN 18-40 WATT LAMPS (234-520W)
OR 13X G9-2.5W LEDS

CLASS I

IP RATING 20

QC RATING 21

VOLTAGE RANGE
110 - 240V

PRODUCT
MARKS &
RATINGS



WEIGHT 10KG
PACKED 16KG
WEIGHT

TECHNICAL DRAWING

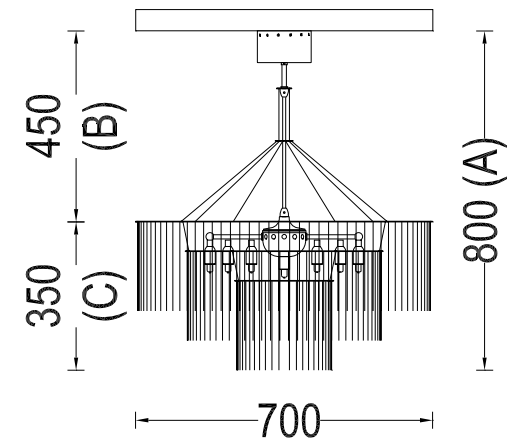

INTERACT

SELECT COLOUR

- SILVER *
- BRASS *
- COPPER *
- SMOKE *
- MIXED METALIC *
- RUST *
- WHITE
- RED
- BLACK

* METALLIC

CUSTOMISE DIMENSIONS

A

B

C

LAMP TYPE

QUANTITY

ADDITIONAL COMMENTS

[WEB LINK](#)

[DOWNLOAD](#)