

PROTEA CHANDELIERS | PROTEA - 700 - SUSPENDED | PROTEA-700-S



DESCRIPTION

A suspended chandelier inspired by the South Africa's national flower the 'Protea'. Made from lasercut stainless steel frames, chrome plated or lacquered, solid brass components and ballchain in several optional finishes. Illuminated by 13 surface mounted G9 Halogen lamps.

PRODUCT SIZE

SHADE SIZE: 700W X 700H MM / TOTAL HEIGHT: 1200MM

PACKAGING DIMENSIONS

810MM(W) X 810MM(L) X 330MM(H)



LAMP TYPE & NO

13 X G9-HALOGEN 18-40 WATT LAMPS (234-520W)
OR 13X G9-2.5W LEDS

CLASS I

IP RATING 20

QC RATING 21



VOLTAGE RANGE

110 - 240V

PRODUCT
MARKS &
RATINGS



WEIGHT 14KG

PACKED 22KG
WEIGHT

TECHNICAL DRAWING

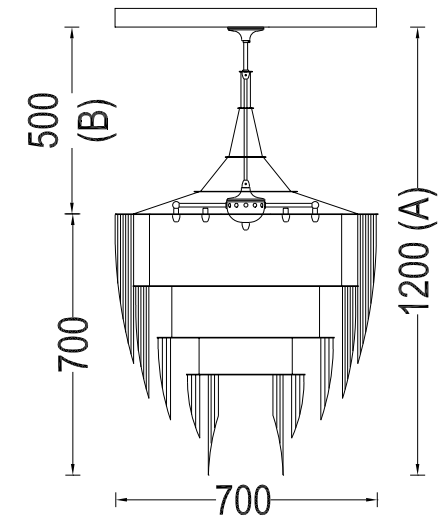

INTERACT

SELECT COLOUR

- SILVER *
- BRASS *
- COPPER *
- SMOKE *
- MIXED METALIC *
- RUST *
- WHITE
- RED
- BLACK

* METALLIC

CUSTOMISE DIMENSIONS

A

B

LAMP TYPE

QUANTITY

ADDITIONAL COMMENTS

[WEB LINK](#)

[DOWNLOAD](#)