

NGOMA DRUM | NGOMA DRUM - 700 - SUSPENDED | NGOMA-700-S



DESCRIPTION

A circular drum shaped chandelier inspired by Venetian wrought ironwork. Made from laser-cut stainless steel frames, chrome plated or lacquered, solid brass components and ballchain in several optional finishes. Illuminated by a suspended arrangement of 13 pyrex glass balls containing G4-Halogen lamps.

PRODUCT SIZE

SHADE SIZE: 700W X 350H MM / TOTAL HEIGHT: 850MM

PACKAGING DIMENSIONS

810MM(W) X 810MM(L) X 330MM(H)



LAMP TYPE & NO

13 X G4-HALOGEN 10 WATT LAMPS (130W) OR 13X G4-2W LEDS. OR 13X E12/14 // E26/27 LEDS

CLASS III
IP RATING 52
QC RATING 21

VOLTAGE RANGE
12V

PRODUCT MARKS & RATINGS



WEIGHT 9KG
PACKED 17KG
WEIGHT

TECHNICAL DRAWING

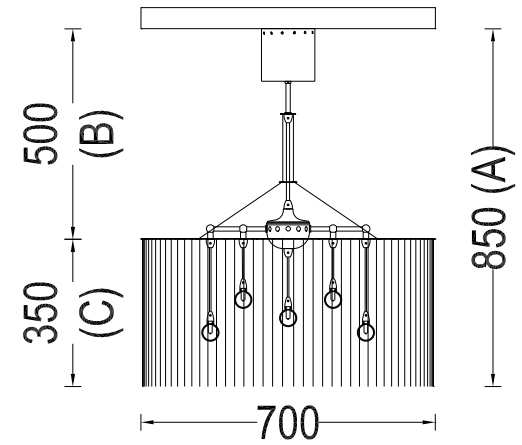

INTERACT

SELECT COLOUR

- SILVER *
- BRASS *
- COPPER *
- SMOKE *
- MIXED METALIC *
- RUST *
- WHITE
- RED
- BLACK

* METALLIC

CUSTOMISE DIMENSIONS

A

B

C

LAMP TYPE

QUANTITY

ADDITIONAL COMMENTS

[WEB LINK](#)

[DOWNLOAD](#)