

# MANDALA NO.2 | MANDALA NO.2 1000MM DIA | MAND-NO2-1000-S



## DESCRIPTION

A massive intense illuminated Mandala sculpture inspired by Islamic patterns which have been translated into three dimensions through the extrusion of the complex interlocking geometry. Made from lasercut stainless steel frames, chrome plated brass components, ballchain. Illuminated by a combination of surface mounted and suspended G4 Halogen lamps. Mandala No.2 is a 'shallower' version than Mandala No.1 with a more evident pattern from any angle

## PRODUCT SIZE

SHADE SIZE: 1000W X 500H MM / TOTAL HEIGHT: 1400MM

## PACKAGING DIMENSIONS

1140MM(W) X 1140MM(L) X 390MM(H)



## LAMP TYPE & NO

24 X G4-HALOGEN 12V 10 WATT LAMPS (240W) OR  
24X G4-2W-LEDS

CLASS III  
IP RATING 52  
QC RATING 21

VOLTAGE RANGE  
12V

PRODUCT  
MARKS &  
RATINGS



WEIGHT 45KG  
PACKED 60KG  
WEIGHT

## TECHNICAL DRAWING

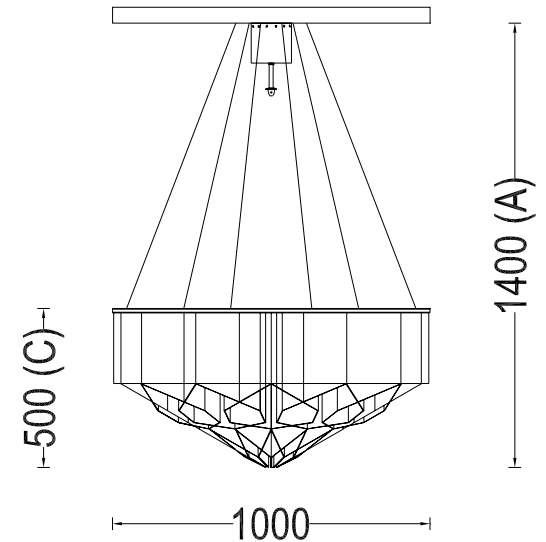

## INTERACT

### SELECT COLOUR

- SILVER \*
- BRASS \*
- COPPER \*
- SMOKE \*
- MIXED METALIC \*
- RUST \*
- WHITE
- RED
- BLACK

### CUSTOMISE DIMENSIONS

A

B

C

### LAMP TYPE

QUANTITY

### ADDITIONAL COMMENTS

[WEB LINK](#)

[DOWNLOAD](#)

\* METALLIC