

FLOWER OF LIFE | FLOWER OF LIFE - WALL SCONCE - 500 | FOLC-500-WS



DESCRIPTION

An extension of the existing 'Flower of Life' chandelier collection now also available as a matching wall sconce. Illuminated by 5x G9-Halogen or G9-LED lamps.

PRODUCT SIZE

SHADE SIZE: 500X340W MM / TOTAL HEIGHT: 940MM

PACKAGING DIMENSIONS

430MM(W) X 600MM(L) X 390MM(H)



LAMP TYPE & NO

5 X G9-HALOGEN 18-40 WATT LAMPS (90-200W) OR
4X G9-2.5W LEDS

CLASS II
IP RATING 20
QC RATING 21

VOLTAGE RANGE
110-240V

PRODUCT
MARKS &
RATINGS



WEIGHT 4KG
PACKED 7KG
WEIGHT

TECHNICAL DRAWING

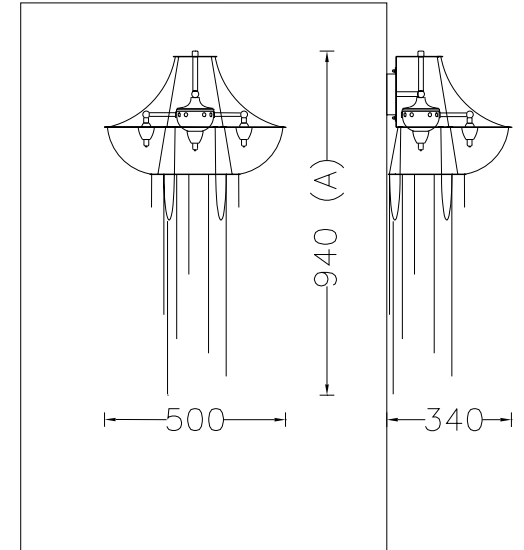

INTERACT

SELECT COLOUR

- SILVER *
- BRASS *
- COPPER *
- SMOKE *
- MIXED METALIC *
- RUST *
- WHITE
- RED
- BLACK

* METALLIC

CUSTOMISE DIMENSIONS

A

B

LAMP TYPE

QUANTITY

ADDITIONAL COMMENTS

[WEB LINK](#)

[DOWNLOAD](#)